

## SHEET PILE CLAMP

PRODUCT CODE: APAC106004



WEIGHT: 5.5KG (12.1LBS)

SURFACE FINISH: HDG

DIMENSION: METRIC (MM)

COMPLIES WITH:

USA STANDARD: OSHA 1926.502(B);

EUROPEAN STANDARD: BS EN 13374:2004 (CLASS A);

CANADIAN STANDARD: OCCUPATIONAL HEALTH AND SAFETY ACT OF ONTARIO; ONTARIO REGULATION 213/91;

AUSTRALIAN /NEW ZEALAND STANDARD: AS/NZS 4994.1

### 1. Floor Slab Thickness $\leq 70$

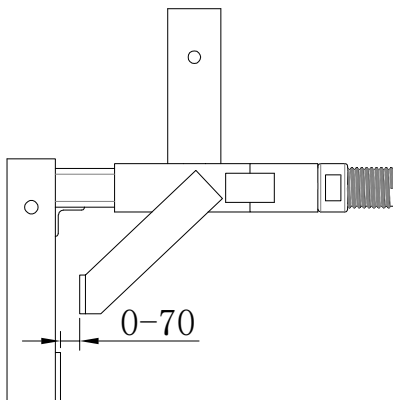

### 2. Floor Slab Thickness $\geq 70$

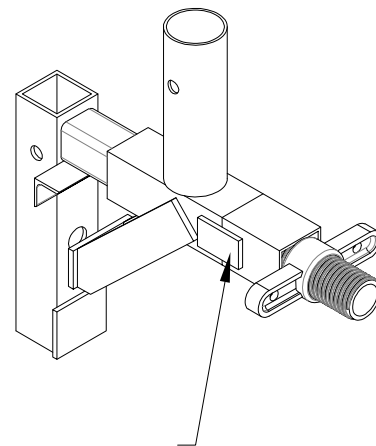
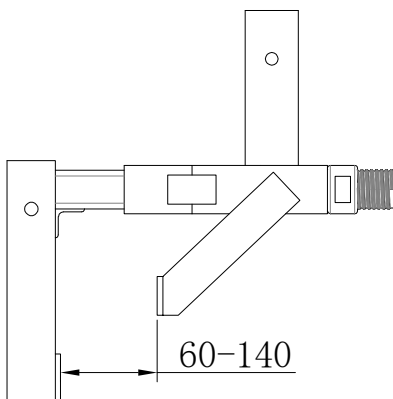

\*Adjust the position of the extension tube according to different scenarios

