

WALKWAY FOOTPLATE

PRODUCT CODE: APAC101031



WEIGHT: 8.5KG (18.74LBS)

SURFACE FINISH: POWDER COATING

DIMENSION: METRIC (MM)

COMPLIES WITH:

USA STANDARD: OSHA 1926.502(B);

EUROPEAN STANDARD: BS EN 13374:2004 (CLASS A);

CANADIAN STANDARD: OCCUPATIONAL HEALTH AND SAFETY ACT OF ONTARIO; ONTARIO REGULATION 213/91;

AUSTRALIAN /NEW ZEALAND STANDARD: AS/NZS 4994.1

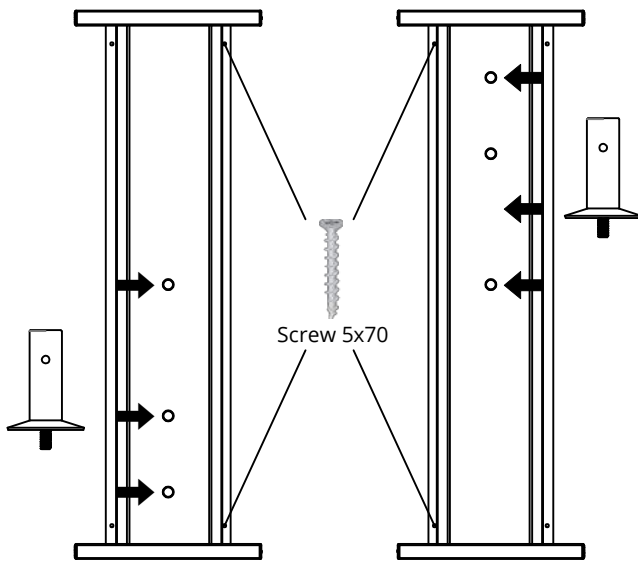
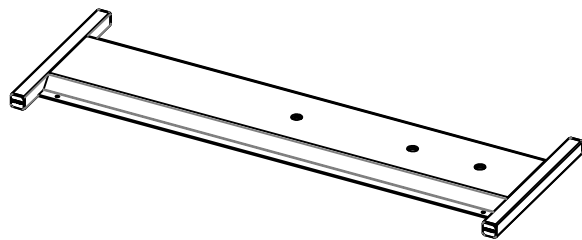
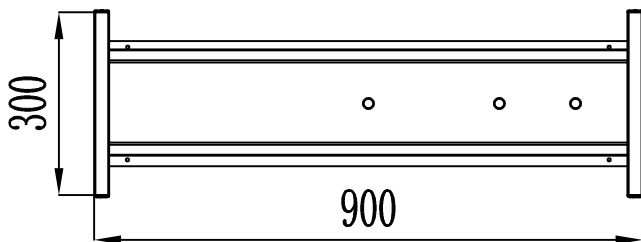

Let footplate be perpendicular to the panel,
Recommended to tighten screws for
non-slipping and strong wind.

