

BARRIER BRACKET 360

PRODUCT CODE: APAC103004



WEIGHT: 0.5KG (1.1LBS)

SURFACE FINISH: HDG

DIMENSION: METRIC (MM)

COMPLIES WITH:

USA STANDARD: OSHA 1926.502(B);

EUROPEAN STANDARD: BS EN 13374:2004 (CLASS A);

CANADIAN STANDARD: OCCUPATIONAL HEALTH AND

SAFETY ACT OF ONTARIO; ONTARIO REGULATION 213/91;

AUSTRALIAN / NEW ZEALAND STANDARD: AS/NZS 4994.1

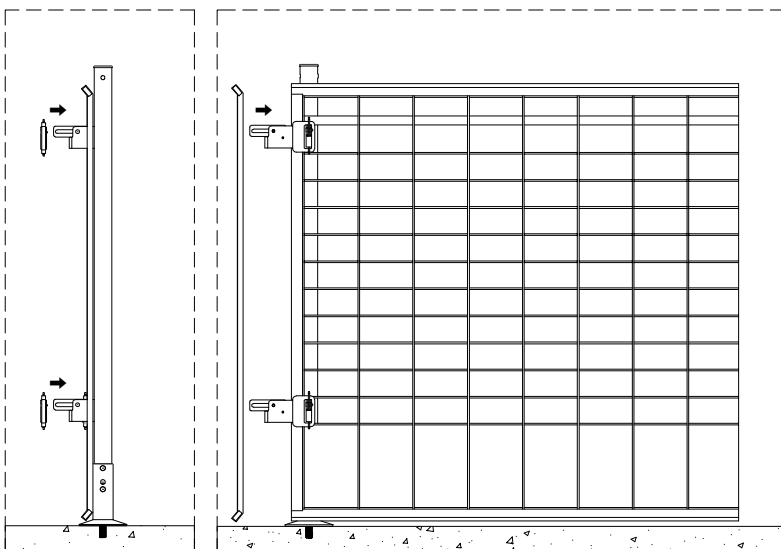
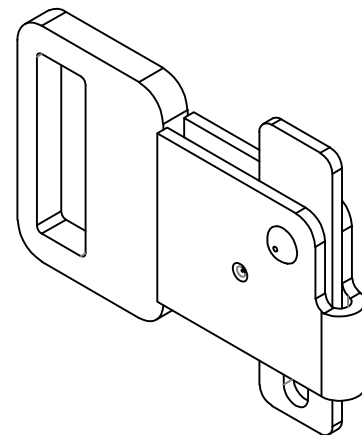
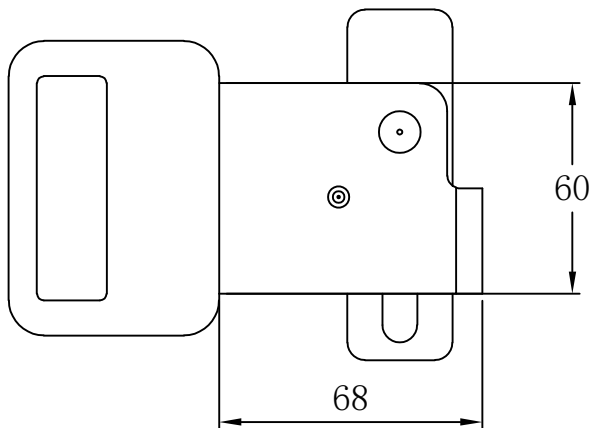

*Barrier bracket 360 is used in corners to eliminate double attachments or posts.

